

OCEANSLED® SERIES RANGER



The OceanSled® Ranger is Shift’s advanced autonomous uncrewed surface vehicle (USV) designed for maritime tasking, modular payloads and rugged operations in the littoral domain. Equipped with the customer in mind, using state-of-the-art sensors, and real-time data integration capabilities, the OceanSled® Ranger is a versatile solution for both materiel movements and Intelligence Surveillance and Reconnaissance.

KEY BENEFITS

- 
IMPROVED DOMAIN AWARENESS: The Ranger realizes its full potential when enabled through CiMS™ software and coupled with a rich sensor suite. The Ranger provides a secure platform for covert and overt missions that can relay real-time information for accurate decisions and timely actions.

- 
EFFICIENT AND USABLE: The Ranger offers an intuitive operating experience for field personnel and remote command centers, reducing training requirements and personnel overhead. Uncrewed missions allow for extended operations and minimizes training and personnel requirements.

- 
MULTI-MISSION FORCE MULTPLIER: The Ranger’s open design allows for deployment of various payloads, even a nested ROV or UAV along with a variety of on-board sensors, offering versatility and allowing your team to do more with less.

FEATURES

- Advanced Sensor Suite
- Autonomous Navigation
- Low Detectability
- High Payload
- Surf/estuary/river capable
- Real-time data capable
- Two way voice communications

APPLICATIONS

- Intelligence Surveillance Reconnaissance
- Maritime/Port Security
- Asset Inspection
- Sonar
- Digital Twinning image capture
- Ship to Ship and Ship to Shore logistics
- Joint Operations (Classified-Unclassified)

CONTINUED ON BACK SIDE

COMPONENTS

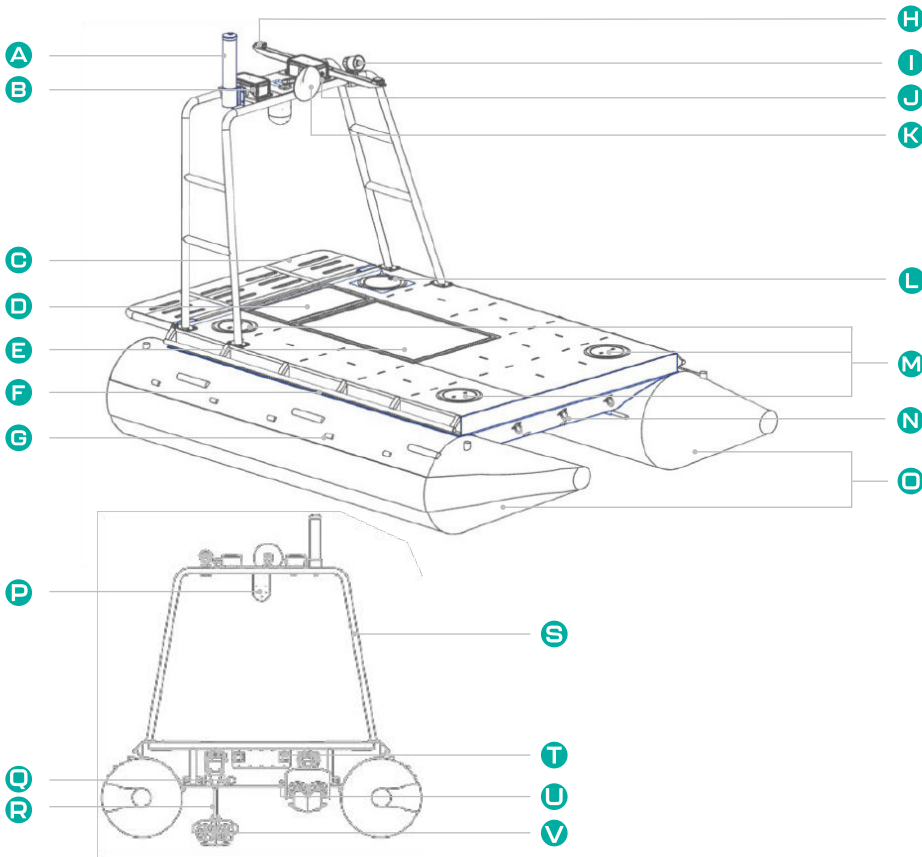

- A** Radio Antenna
- B** Radio Box
- C** Deck Extension
- D** Control Box Compartment
- E** Battery Compartment
- F** Attachment Rail
- G** Pontoon Attachment Straps
- H** GPS Antenna
- I** Loud Hailer
- J** Comms Box
- K** Parabolic Mic
- L** Power Switch/Charging Compartment
- M** Inspection Hatch
- N** Tow Point
- O** Pontoon
- P** PTZ Camera
- Q** Scupper Drain
- R** Thruster Leg
- S** Sensor Arch Frame
- T** Cable Seals
- U** Thruster: Kick-up Mode
- V** Thruster: Drive Mode

PRODUCT SPECS

ELECTRICAL

Battery Power (up to three)	48VDC, LiFePO4 Battery, 96 Ah, Smart Battery Management
-----------------------------	---

PHYSICAL

Length Overall	3.6m (11.10")
Length On Deck	2.3 m (7'5") ext 2.8m (9'1")
Beam	2.2 m (7.4')
Deck Area	3.8m ² (41ft ²) ext 4.6m ² (50ft ²)
Displacement	280 Kg (616 lbs)
Operating Temperature	0-40°C
Max Speed	6 knots (11 km/h)
Payload	454 kg (1000 lbs)

SENSORS & COMPONENTS

Propulsion	4 x 1.2kW DC Brushless Thrusters 2 x 6kW Upgrade Option
Lights	Transport Canada Compliant Navigation Lights
Auto-Pilot	3 x IMUs, 2 x Barometers
Handheld Controller	900 MHz, LOS
Camera	1080p, 20x Optical Zoom, 360°pan, 135° tilt
Field Control Center	Custom Pelican Case with full featured PC and Controller

OPERATIONAL

Launch & Recovery	Beach or boat/ship
Transport	Trailer
Sea State	Up to Beaufort Level 6